



Land Rover Accessories

Fall 2023 Price List

BRITPART

The quality parts for Land Rovers

TerrafirMa

Serious 4x4 Accessories



TF100 - Anthracite RVS alloy bead lock wheel for DEF/D1/RRC

Defender All
Range Rover Classis
Discovery 1989-1998

Was 87.00KWD

NOW 62.00KWD

Super strong 1300kg rating, the unique Terrafirma alloy bead lock wheel allows the tyre to be fitted conventionally for a strong on or off-road wheel. When very low tyre pressures are required and the risk of rolling the tyre off the rim is high then the tyre can be fitted onto the outside of the wheel and retained with the bead lock ring.

90/110/130/D1/RRC 7x16 ET10



TF103A - Anthracite RVS alloy bead lock wheel 7x16 for DEF/D1/RRC inc. wheel nuts

Defender All
Range Rover Classis
Discovery 1989-1998

Was 209.71KWD

NOW 170.50KWD

The Terrafirma bead lock ring kit converts the Terrafirma bead lock wheel from a conventional on and off road wheel to full bead lock capability by clamping the tyre to the outside of the rim.

Kit includes 1 ring and nuts & bolts



TF102 - TF RVS BEADLOCK WHEEL - MATT BLACK - Suitable for DEF, Discovery 1 & RRC From TERRAFIRMA

Defender All
Range Rover Classis
Discovery 1989-1998

Was 78.90KWD

NOW 64.50KWD

Super strong 1300kg rating, the unique Terrafirma alloy bead lock wheel allows the tyre to be fitted conventionally for a super strong on or off road wheel. When very low tyre pressures are required where the risk of rolling the tyre off the rim is high then the tyre can be fitted onto the outside of the wheel and retained with the bead lock ring.

90/110/130/D1/RRC 7x16 ET10



DA2432G - 16X8 Black Gloss Zu Land Rover Alloy Wheel 38mm Off-set

Discovery 2
Range Rover P38

Was 70.53KWD

NOW 40.00KWD

Super strong, Super light

> 38mm + VE offset

> 1,400kg rating

> 12.0kg each

> TV approved and meets or exceeds UK - European - U.S. - Canadian - Australian - South African and Japanese wheel manufacturing specifications

> Uses standard Land Rover alloy wheel nuts

> Easy to balance

> Manufactured in the UK

Note - Wheel nuts and centre caps not included.



GRW004 - STEEL WHEEL - MODULAR - WHITE

Defender All

Range Rover Classis

Discovery 1989-1998

Was 17.80KWD

NOW 14.50KWD

The most popular alternative wheels for Land Rovers, the Modular wheel is strong and dependable.

90/110/130/D1/RRC 7x16 ET08



GRW001 - STEEL WHEEL - 8 SPOKE - WHITE

Defender All

Range Rover Classis

Discovery 1989-1998

22.50KWD

The most popular alternative wheels for Land Rovers, the 8 spoke wheel is strong and dependable.

90/110/130/D1/RRC 7x16 ET00



DA3187G - 16" X 7 White with red and blue stripes

Defender All

Range Rover Classis

Discovery 1989-1998

27.50KWD

Smarten up your Land Rover with a smart new set of wheels.

16 x 7 White with red and blue stripes

8-spoked - welded tubeless



TF152 - TF 18 X 8 STEEL WHEEL - D3/D4/RRS

Discovery 3 LR3 2005-2009

Discovery 4 LR4 2010-2016

Range Rover Sport 2005-2009

36.00KWD

This 8 hole heavy duty modular steel wheel is perfect for Off Road and Expeditionary use in your Land Rover Discovery 3 & 4 plus the Range Rover Sport 2005 onwards.

D3/D4/RRS

8X18, ET45, Load Rating 1500KG, PCD 5x120

Please note that OE wheel nuts will not fit with these wheels, but the wheels are supplied with suitable wheel nuts.

Will fit vehicles fitted with 320mm discs. If vehicle has 340mm discs TF303 wheel spacers are required



DA6548G—Terra Firma Defender 18x8 Gloss Black Iconic Alloy Wheel

Defender All

83.50KWD

The iconic Defender alloy wheel in 18 inch black gloss.

These wheels really fill out the wheel arch of the Defender and are a great upgrade to any vehicle. These will fit all Defenders (except ones fitted with brake drums).



DA6634G—Terra Firma Defender 16x7 Diamond Cut Iconic Alloy Wheel

Defender All

109.00KWD

The iconic Defender alloy wheel in 16 inch Diamond Cut gloss black.

These wheels really fill out the wheel arch of the Defender and are a great upgrade to any vehicle.

These will fit all Defenders (except ones fitted with brake drums).



DA2694G - 16 x 8 Black Steel Wheel

Defender All

83.50KWD

Smarten up your Land Rover with a smart new set of wheels.

A large offset steel rim to fit traditional Land-Rover axles. In the style of a 1-ton rim but 8 inches wide to fit larger modern tubeless tyres.

Note - It is the responsibility of the vehicle owner to ensure that the wheels fitted to their vehicle have an appropriate load rating. The minimum required load rating can be determined by taking the manufacturers recommended maximum axle weight and dividing by two.



GRW006- STEEL WHEEL - MODULAR - BLACK

Defender All

Range Rover Classis

Discovery 1989-1998

25.50KWD

The most popular alternative wheels for Land Rovers, the Modular wheel is strong and dependable.

90/110/130/D1/RRC 7x16 ET08

TF302 - WHEEL SPACERS 30MM - D2 / P38

Discovery 2 1998 - 2004
Range Rover 1995 - 2002

52.50KWD



Terrafirma 30mm alloy wheel spacers complete with high tensile studs and a complete set of retaining nuts

5x120 PCD. (Set of 4)

TF303 - WHEEL SPACERS - 30MM - VARIOUS MODELS

DISCOVERY 3 LR3 2005 - 2009
DISCOVERY 4 LR4 2010 - 2016
RANGE ROVER 2002 - 2012
RANGE ROVER SPORT 2005 - 2013

52.50KWD



Terrafirma 30mm alloy wheel spacers complete with high tensile studs and a complete set of retaining nuts

5x120 PCD. (Set of 4)

These quality wheel spacers include the important wheel location spigot.

DA5004G - WHEEL SPACERS 30MM

Defender All
Range Rover Classis
Discovery 1989-1998

90.00KWD

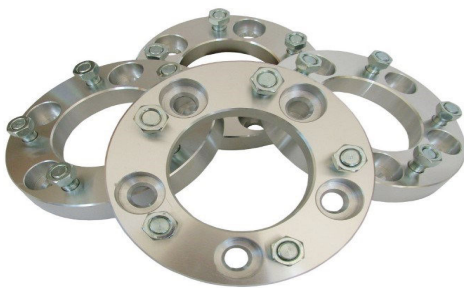

Improve your Land Rover's appearance, steering lock and handling with a set of wheel spacers.

30mm thick
Steel machine finish
Complete with wheel nuts and OEM studs



RRD500560G— Wheel Nut Sliver

3.00KWD



RRD500560GBG—Wheel Nut Black

2.50KWD

Factory fitted brake lines are usually made of rubber. Even when new, rubber expands under pressure causing a decrease in braking performance and spongy pedal feel.

Terraforma Goodridge brake hoses won't expand under pressure, delivering precise braking when you need it.

Every Terraforma Goodridge brake line is individually 100% pressure tested and guaranteed to be leak free.

Terraforma Goodridge brake lines are corrosion resistant and come with a lifetime guarantee.

Every brake line kit is supplied with all fixings required to provide a perfect fit first time, every time!



TF644GD - TF GOODRIDGE BRAKE HOSE KIT - +2"

Defenders All

Was 25.10KWD

with ABS 2004 onwards

NOW 20.50KWD



TF645GD - TF GOODRIDGE BRAKE HOSE KIT - +2"

Defenders All

Was 15.77KWD

without ABS 2004 onwards

NOW 13.00KWD



TF208 - TF SUSP. KIT - MEDIUM LOAD - 90/D1/RRC

Range Rover Classic
Discovery 1989—1998
Defender 1983—2006
Defender 2007 onwards

187.50KWD

Terraforma suspension kit including a pair of 2 inch lift TF018 front & TF023V rear springs
Plus 2 inch TF120 front & TF121 rear +2 inch Pro Sport shocks.



DA8910G - OLD MAN EMU COIL SPRINGS

Defender All
Range Rover Classis
Discovery 1989-1998

Was 51.39KWD

NOW 42.00KWD

Front Lift - Up to 40mm

Spring rate - 225lbf/in / 39N/mm. Free height - 390mm

Manufactured from state of the art micro-alloyed spring steel for superior strength and durability.

Exceptional resistance to sagging and corrosion.



DA8922G - OLD MAN EMU COIL SPRINGS

Defender - 110
Defender - 130

Was 51.39KWD

NOW 42.00KWD

Front Lift - Up to 50mm

Spring rate - 300lbf/in / 39N/mm. Free height - 435mm

Manufactured from state of the art micro-alloyed spring steel for superior strength and durability.

Exceptional resistance to sagging and corrosion.



DA8921G - OLD MAN EMU SHOCK ABSORBER

Rear

Defender - 90 & 110

Discovery 1

Range Rover Classic

40.50KWD

Nitrocharger Sport shock absorbers introduces advanced dual-stack deflective disc technology that continuously adapts to the terrain, offering rapid response improvements to ride quality, handling and control.

Open length - 560mm

Closed length - 346mm



DA8925G—Old Man Emu Defender Steering Damper

Defender All

39.50KWD

Steering dampers with nitrogen charged foam cell for reduced wheel vibration and improved handling and control.



DC5005G - BRITPART SUPER GAZ - STEERING DAMPER

Discovery 1

Range Rover Classic

13.00KWD

Britpart Super Gaz Shock Absorbers offer a 35mm bore tube filled with Fuchs shock -absorber fluid, using the best seal available, single piece eye rings, polyurethane bush mounts and a very durable powder coated finish.

These offer a vast improvement in ride quality and damping performance.

TF835 - TF RETURN TO CENTRE STEERING DAMPER

Defender All

30.50KWD



TerraFirma Defender RTC (return to centre) steering damper.

Features include:

30mm internal bore, Mono tube design

12.5mm double chromed shaft, 50/50 damping, Coil-over design



DA2353G - FRONT RADIUS ARM TO CHASSIS KIT

Rubber bush kit

Was 3.65KWD

NOW 3.00KWD

Defender - 1987 - 1997

Discovery 1

Range Rover Classic - 1986 - 1994

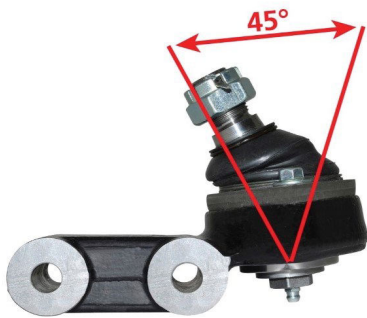

DA1129ULTRAG - FULCRUM BRACKET WITH HIGH ARTICULATION

Defender

30.50KWD

Discovery 1

Range Rover Classic

One of the major factors limiting the rear suspension movement on vehicles fitted with an A-frame is the standard ball joint. We have developed this part to provide significantly more articulation than the standard and most aftermarket joints. Others claim more articulation yet in reality they offer very little over the standard 30°.

This exclusive ball joint offers 45° movement in all directions. It is easily adjustable with a regular hex spanner and has a grease nipple for convenient regular maintenance.

It is supplied fitted in the mounting bracket ready to bolt to your Land Rover.



NTC7307PY-YELLOWG - RADIUS ARM TO AXLE

Yellow bush set

Was 7.40KWD

Front

NOW 6.50KWD

Defender - 1987 - 2006



DA7531 - FULLY ADJUSTABLE SUSPENSION LIFT ROD KIT

Discovery 3

Was 55.00KWD

Discovery 4

NOW 32.50KWD

Range Rover Sport - 2005 - 2013

These adjustable rods replace the plastic and rubber parts Land Rover supply on the vehicle. Made from aluminum with an industrial heavy grade rubber bushing, the aluminum parts are anodized black to help with corrosion protection and blending in when in the garage for work.

The lift rods have two settings; standard and off-road. With the vehicle set to normal driving height the shortened rods will give you off-road height. If you select off-road height the vehicle will be in the 'super extended' position as standard if you use the 'shortened' settings.

No tools are required and should take no more than 2 minutes to do all four rods. Access to the front is over the front wheels and for the back is through the rear wishbones (blanket required!)



TF250 - TF H/D STEERING RODS - DEF

Defender All

56.00KWD

Terrafirma zinc plated solid steel heavy duty steering rods with 3 greaseable track rod ends.



TF1020 - PAIR OF TF EXTENDED BUMP STOPS

Defender All

Was 18.91KWD

Discovery 1989—1998

NOW 15.50KWD

Range Rover Classic



DA2355G - DIFF COUPLING SHAFT

Range Rover L322 - 2002 onwards

Was 48.74KWD

NOW 40.00KWD

Range Rover L322 - 2002 onwards, suffer from a common problem with the coupling shaft spline wearing between the front prop shaft and front differential, thus losing drive to the differential. The problem purely relates to the coupling shaft and the differential itself is not affected. Currently the only solution offered by Land Rover is to replace the prop shaft and the whole complete front differential assembly - a very expensive option!

We are now able to offer a cheaper alternative! Using this new coupling shaft will enable you to replace just the prop shaft and coupling shaft and leave the differential in place, therefore reducing both time (the differential need not be removed from the vehicle) and cost.



DA5100G - TOW HITCH

17.50KWD

DA5726G - MOMO QUARK STEERING WHEEL

Black/ air leather

350mm

90.00KWD

Requires Steering Wheel Boss kit to fit



DA5734G - MOMO 36 SPLINE BOSS

Defender - up to FA

34.00KWD



DA5735G - MOMO 48 SPLINE BOSS

Defender - up to FA

33.50KWD

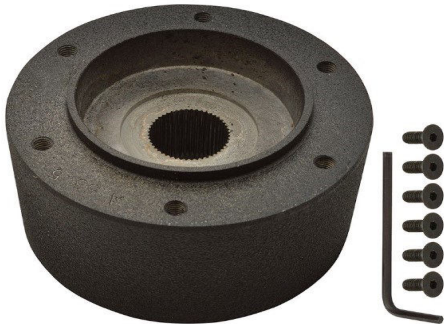

DA5736 - MOMO 48 SPLINE BOSS

Defender - FA onwards

31.50KWD



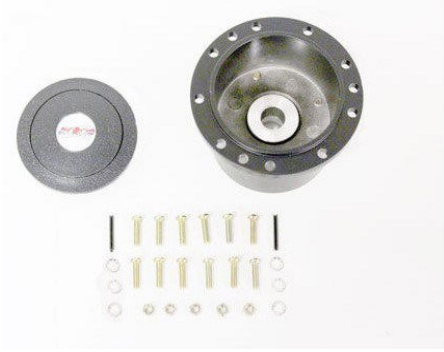

GI002—STEERING WHEEL BOSS WITH 36 SPLINES

This Boss fits the following vehicles -

Was 15.12KWD

Defender 90 / 110 up to 1991 / vin HA906579

NOW 10.50KWD

and then from 1998 / vin WA138480

Range Rover Classic - Non airbag models.

Discovery 1 up to vin LA081991

Steering Wheel Boss for 16mm width & 36 spline steering columns to allow fitment of after market steering wheels.



DA7304G - SPARCO SEAT

Black/Black fabric

Single

116.00KWD

Defender - excluding truck cabs*

Requires seat runner kit and mounting brackets to fit

The R100 is Sparco's latest incarnation of groundbreaking steel-model seats. It features redesigned bolsters for greater support and new padding configurations for improved comfort.

It has been built with comfort and support in mind but it's lower side bolsters and slightly narrower steel frame allow it to fit into vehicles where fitting seats with larger side bolsters may be difficult. The seat features backrest harness slots so that it can be used with a race type harness or normal seatbelts. The seats can be reclined using the double adjuster lever. Made from a durable fabric, the R100 is available in single tone or duo-tone styles. Duo-tone styles feature contrasting side accenting and stitching to match any interior.

The Sparco R100 Seat range is designed to attach using Sparco vehicle specific seat mounts



DA7306G - SPARCO SEAT RUNNERS

Defender - excluding truck cabs

For fitment of DA7304—Sparco Seat

15.50KWD

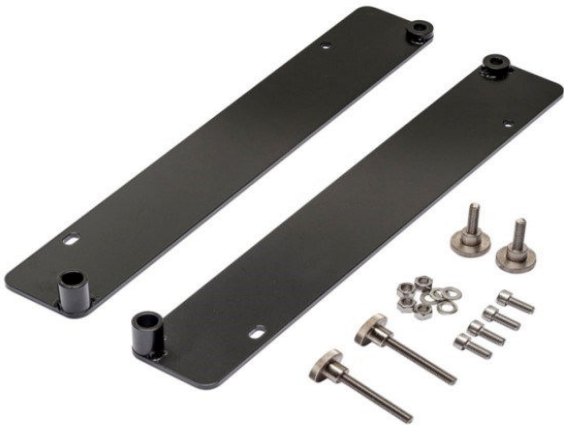

DA7307G - SPARCO REMOVABLE MOUNTING KIT

Defender - excluding truck cabs

For fitment of DA7304—Sparco Seat

23.50KWD



DA2035MESHG - CUBBY BOX

Top - Black mesh

Body - Black

Defender

Series 3

31.00KWD

With a Britpart cubby box in your Land Rover you can ensure your vehicle remains clutter free with these handy storage devices.

Now with a double cup holder as standard, spilt drinks are a thing of the past.



DA5498G - GEARBOX GAITER

Grey

Defender

Was 6.30KWD

NOW 5.00KWD



DA2603G - GLOVE BOX KIT

Normal interior finish fascia plate

Suitable for right & left hand drive models

Defender - 2007 onwards

24.50KWD

Neat storage solution.

This glove box is for the Defender which utilizes the available dashboard space.

Ideal for storing all the usual small items you carry with you.

Robust construction and easy to fit with all the necessary parts supplied.



DA2444G - DOOR CASING

Front - RHS

Electric window

Black

Defender - up to 2007

Was 29.07KWD

NOW 24.00KWD

Replace your Defender's old tatty door casing with one of these smart plastic replacements.



FBKIT01-07/B—BONNET CHEQ PLATE - BLACK

Defender 2007 onwards

Was 140.14KWD

NOW 95.000KWD



DA4343G - BONNET PROTECTOR

Satin black finish

Was 53.20KWD

Kit

NOW 43.50KWD

Defender - 2007 onwards



DA4049BG - WING TOPS

Pair

Satin black finish

25.50KWD

Defender



DA4049G - WING TOPS

Pair

Natural aluminum finish

18.50KWD

Defender

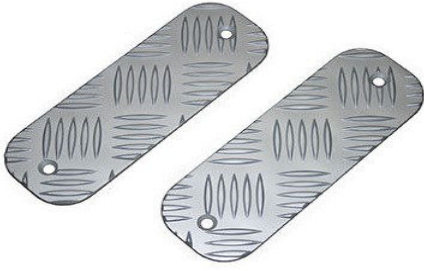

BTS-KIT/B—BUMPER TREADPLATE PAIR

Black anodized bumper tread plate kit
with fittings

Was 5.37KWD

Defender All

NOW 4.50KWD



SLKIT01-VAN/B—SIDE SILLS CHEQUER PLATE - BLACK

DEFENDER 90

Was 40.99KWD

NOW 28.00KWD



DA4072G - SILLS

Pair

Was 22.00KWD

Natural aluminum finish

NOW 8.50KWD

Defender 90

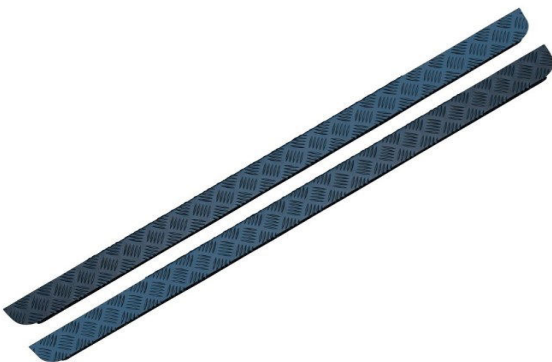

DA4072B - SILLS

Pair

Satin black finish

17.00KWD

Defender 90



TF8220 - SIDE SILLS PAIR - BLACK

Pair

Satin black finish

Defender 90

42.50KWD

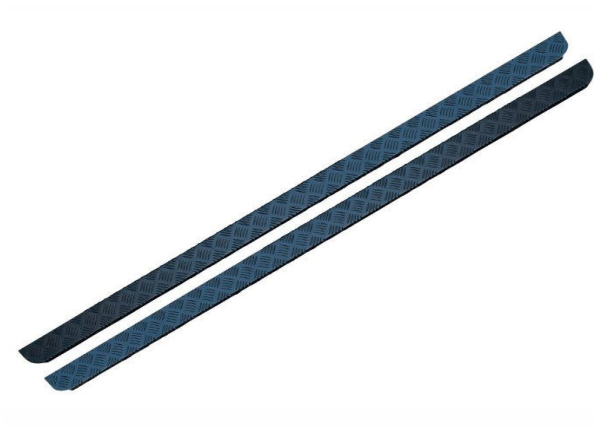

DA4100BG - SILLS

Pair

Satin black finish

Defender 110

23.50KWD



LR008379G—FIRE & ICE STYLE SIDE STEPS

Pair

Black with rubber and anodized

aluminum top

Defender 90 – 2003 onwards

Defender 110 – 2-door pick-up – 2003 onwards

Was 104.93KWD

NOW 85.50KWD



LR008379BG - FIRE & ICE STYLE SIDE STEPS

Pair

Black steel with rubber and anodized

aluminum top

Defender 90 – 2003 onwards

Defender 110 – 2-door pick-up – 2003 onwards

123.50KWD



VPLGP0226G - SIDE STEPS

Pair

Range Rover Sport - 2014 onwards

Range Rover L405

138.50KWD



DA4073G - REAR WING PROTECTOR

Pair

Was 9.08KWD

Natural aluminum finish

NOW 7.50KWD

Defender 90



DA4073BG - REAR WING PROTECTOR

Pair

Satin black finish

Defender 90

11.50KWD

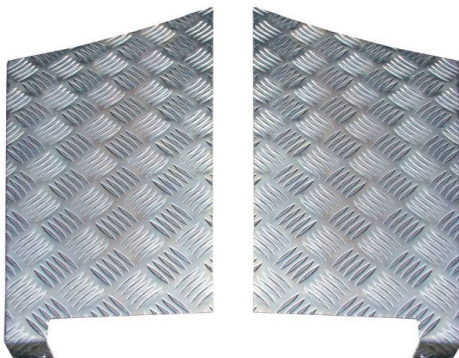

DA4071G - REAR WING PROTECTOR

Pair

Was 11.61KWD

Natural aluminum finish

NOW 9.50KWD

Defender 110



DA4071BG - REAR WING PROTECTOR

Pair

18.00KWD

Satin black finish

Defender 110

RQKIT01-110/B - QUADRANT CHEQUER PLATE PAIR - BLACK

Pair

Was 14.09KWD

Satin black finish

NOW 11.50KWD

Defender 110



CNKIT01-90/B - REAR CORNER KIT - BLACK

CHEQUER PLATE KIT

Was 13.26KWD

Defender 90

NOW 11.00KWD

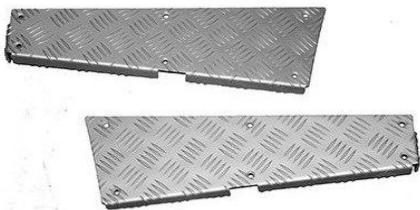

RCMKIT01-DEF/A - CROSS MEMBER CHEQUER PLATE - SILVER

Defender All

26.50KWD





DA5507LHDG - STEERING/SUMP GUARD

LHD

Aluminum - main plate - 8mm thick
brackets - 8mm thick

96.00KWD

Defender - 1985 - 2006 & 2007
onwards



DA5508G - STEERING/SUMP GUARD

RHD & LHD

Aluminum - main plate - 8mm thick
brackets - 8mm thick

Was 51.96KWD

NOW 42.50KWD

D1/RRC

This guard from Britpart is manufactured from high-quality, hard-wearing and corrosion resistant material to counteract any unforeseen obstacles your Land Rover may encounter whilst off-roading. All fixings are supplied and the guard fits into the vehicle's pre-existing holes. The guard has holes at the front to allow for water drainage and also to help with ventilation for the cooling system.



DA1435G—SEAT BOX PROTECTOR

Pair Black

Was 8.01KWD

NOW 7.00KWD

Defender All



DPT100070G - BUMPER RUBBER END CAP

Single

Defender

8.50KWD

Does not include fixings



DA1968G - XS FRONT GRILLE & HEADLIGHT SURROUND

Black with silver mesh

Defender

Does not come with fixing kit

Was 69.12KWD

NOW 56.50KWD

The XS Enhancement range from Britpart is the perfect way to give your Defender a fresh new look. The front grille, side grille and bonnet vent designs are exclusive to Britpart.



DA5108B—RADIATOR GRILLE

Black

Range Rover L322

Was 69.73KWD

NOW 57.00KWD



LR038615G - GRILLE - RADIATOR - BLACK - PLASTIC

Black

Plastic

DEFENDER 1986 - 2006

DEFENDER 2007 ONWARDS

4.50KWD



TF270 - FRONT GRILL AND HEADLIGHT SURROUNDS

Gloss Black

85.50KWD

Plastic

Defender All

Replace and update the look of your Land Rover Defender with this stylish Sport front grill & head lamp surround.

Will fit directly onto the pre-existing mountings.



TF271LH - AIR INTAKE GRILLE VENT

Left

Black

12.50KWD

Plastic

Defender All

Will fit directly onto the pre-existing mountings.



TF272 —BONNET VENTS

Black

31.00KWD

Plastic

Defender All

Will fit directly onto the pre-existing mountings.



DA4000G - AIR INTAKE GRILLE

Black steel

Left hand

Single

Defender

Fixing kit not supplied

Was 4.15KWD

NOW 3.50KWD



DA4001G - AIR INTAKE GRILLE

Black steel

Right hand

Single

Defender

Fixing kit not supplied

Was 4.15KWD

NOW 3.50KWD



DA4000SSG - AIR INTAKE GRILLE

Stainless steel with stainless steel screw kit

Left hand

Single

Defender

Was 7.74KWD

NOW 6.50KWD



DA4001SSG - AIR INTAKE GRILLE

Stainless steel with stainless steel screw kit

Right hand

Single

Defender

Was 7.65KWD

NOW 6.50KWD



DA1975G—XS BONNET VENTS

Silver with black mesh

Was 14.99KWD

Defender

NOW 12.50KWD

Fixing kit not supplied



DA1970G - XS AIR INTAKE GRILLES

Black with silver mesh

RHS

13.50KWD

Defender

Fixing kit not supplied



DA1971G - XS AIR INTAKE GRILLES

Silver with black mesh

RHS

12.50KWD

Defender

Fixing kit not supplied



VUB504110G - REAR LIGHT GUARDS

Pair

Was 13.65KWD

Round

NOW 11.50KWD

Defender All



TF1038—Raised air intake for Defender with RH air inlet

Impact resistant MDPE (medium density polyethylene)

Defenders 1994 – 2016 fitted with 300tdi, Td5, 2.4 and 2.2 Puma engines.

94.00KWD



DA3069G - SAFARI RAISED AIR INTAKE

Snorkel fitment side - RHS

Defender - Td5 - 1999 onwards

Was 72.95KWD

Defender - 2007 onwards

NOW 60.00KWD



DEF8MB—WHEEL ARCH KIT - WHEEL ARCH

Gloss Black

Defender 1986 onwards

Was 99.00KWD

NOW 58.00KWD



TF666 - TF WIND DEFLECTORS FRONT

Pair

13.50KWD

DEFENDER ALL



TF667 - TF WIND DEFLECTORS REAR

Pair

Was 12.54KWD

NOW 9.00KWD

DEFENDER 1986

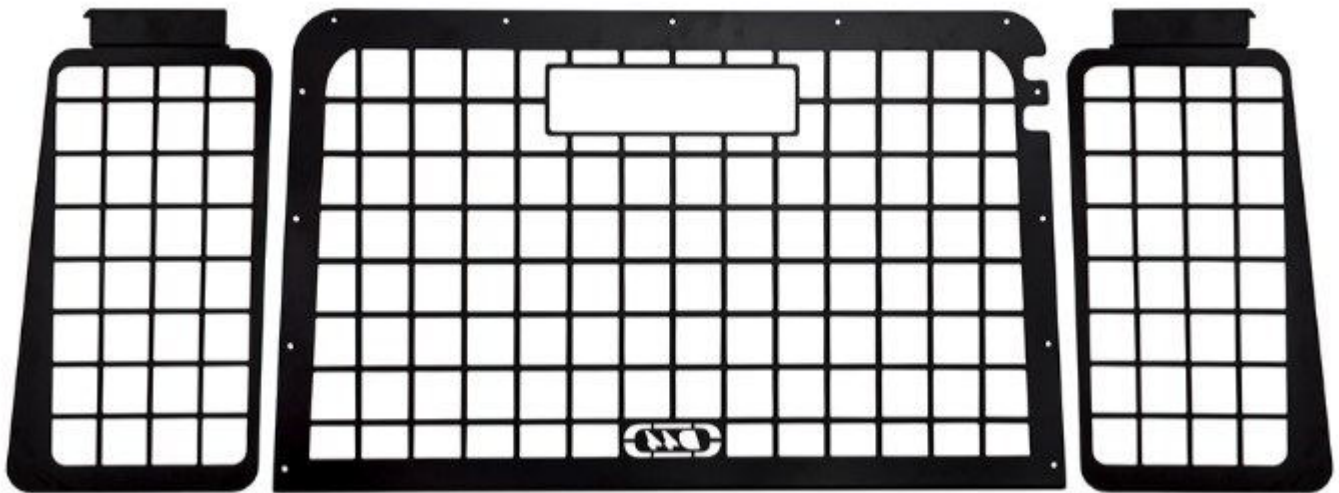

DA1586G - INTERNAL REAR WINDOW GUARD SET

3 guards

Defender 90 - 2002 onwards

103.00KWD

Defender 110 - 2002 onwards

Window guards for the small quarter windows at the rear of the vehicle and the tailgate door offering protection to the glass.



CAT500010PCLG - REAR MUDFLAPS

Pair

Was 16.28KWD

Unpainted bumper

NOW 11.50KWD

Discovery 3

Discovery 4



LR055332G —REAR MUDFLAP

PLAIN

RHS

6.50KWD

Defender 90



LR055332 —REAR MUDFLAP

PLAIN

Was 15.24KWD

RHS

NOW 12.50KWD

Defender 90



LR055340G —REAR MUDFLAP

PLAIN

LHS

6.00KWD

Defender 90



LR055323G—FRONT MUDFLAP

RHS

Defender 90

Defender 110

Defender 130

6.50KWD



LR055330G—REAR MUDFLAP

RHS

Defender 110

Defender 130

8.50KWD



LR055334—REAR MUDFLAP

LHS

Defender 110

Defender 130

8.50KWD



STC7631MTG - SIDE STEP - FOLDING

Rubber tyre tread pattern

Single

Defender - up to 2007

24.00KWD



STC7632MTG—REAR DOOR STEP - FOLDING

Rubber top

Tyre tread pattern

Defender - all models - up to 2007

15.50KWD



DA2232G - SWING AWAY REAR DOOR
MOUNT SPARE WHEEL CARRIER

Defender - all models

Was 104.72KWD

NOW 85.50KWD

TF051 - SWINGAWAY SPARE WHEEL CARRIER

Black powder coated, fabricated steel spare wheel carrier

Defender - all models

122.50KWD



DA2274G - SWING AWAY REAR DOOR
MOUNT SPARE WHEEL CARRIER

With half door tailgate

Defender

115.50KWD



DA2274CABLE - REPLACEMENT CABLE

Suitable for DA2274

Was 5.00KWD

NOW 2.50KWD



TF980 - TF REAR LADDER - DEFENDER

Defender All

Was 45.45KWD

NOW 37.00KWD



DA3073BG - ROOF ACCESS LADDER

Black

Defender 90

Defender 110

34.50KWD



STC50134G - ROOF RACK LADDER

DISCOVERY 2 1998 - 2004

25.00KWD



TF973 - TF REAR ACCESS LADDER

DISCOVERY 3 2005 - 2009

DISCOVERY 4 2010 - 2016

124.50KWD



DA2166G - JERRY CAN

20 litres

Was 6.02KWD

NOW 5.00KWD



DA2182G - JERRY CAN HOLDER

Suitable for 20 litre jerry cans

Was 8.72KWD

NOW 7.50KWD

DA4546G - LONG RANGE FUEL TANK

RHS

Rear arch metal spare fuel tank

45 litres

170.50KWD

Defender 110 - 1999 onwards (Td5 & Puma models)

Not suitable for Defender 130.

Additional bracket required for 7 seater.



DA4546KITG - LONG RANGE FUEL TANK SEAT BELT BRACKET

Was 13.60KWD

NOW 9.50KWD

Tank DA4546 will require this additional bracket when fitting to a Defender 7-seater.



DA1152G - BILLET BONNET HINGES

Was 21.55KWD

Silver anodized finish

NOW 17.50KWD

Defender

Replace your corroded Defender bonnet hinges with a pair of these smart CNC machined aluminum billet hinges which won't tarnish like the standard brackets.

Kits include hinges, hinge bushes and stainless steel bolts.



DA1152SSG - STAINLESS STEEL BONNET HINGES

316 Stainless Steel and polished

Was 29.22KWD

Defender

NOW 24.00KWD

Replace your corroded Defender bonnet hinges with a pair of these smart hinges .

Kits include hinges, hinge bushes and stainless steel bolts.



DA1142G - BILLET WINDSCREEN BRACKETS

Silver anodized finish

Replace your corroded Defender windscreen brackets with a pair of these smart CNC machined aluminum billet brackets which won't tarnish like the standard brackets.

Was 22.57KWD

Defender

NOW 18.50KWD

Kits include gaskets and bolts.

For fitment to vehicles with hinge type windscreen 2 x reinforcement strap LR016671 are required.



DA1142SSG - WINDSCREEN BRACKETS

Pair

Stainless steel

Replace your corroded Defender windscreen brackets with a pair of stainless steel brackets. Cast from marine grade 316 Stainless Steel and polished.

Was 31.16KWD

Complete with fixings.

NOW 25.50KWD

Defender

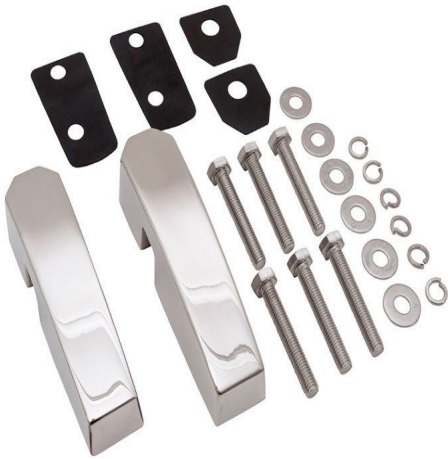

DA5654G - DOOR HANDLE SURROUND

Plastic - chrome finish

Was 21.11KWD

Set of 4

NOW 17.50KWD

Enhance your Range Rover's appearance!

Range Rover L322



DA5658C - DOOR HANDLE COVER

Was 25.39KWD

Plastic - chrome finish

NOW 21.00KWD

Set of 4

Range Rover Sport - Mk1



DA6283G - BRITPART LYNX EYE LED HEADLIGHTS

Left hand drive

Pair

144.00KWD

Light source - 8pcs CREE(XML-10W) LED

Durable polycarbonate lens & die-cast aluminum housing provide maximum protection

Defender All



DA1291G - DELUXE LED CLEAR LIGHT KIT

High quality LED 73mm LED style light

Defender - 1987 - 2007

Series 2

90.50KWD

Series 3

It is a plug and play fitment for Defenders after 1998. Earlier vehicles require soldering or connectors fitting.



DA1191G - CLEAR LED LIGHT KIT

High quality LED 73mm LED style light

Defender - 1987 - 2007

Series 2

56.00KWD

Series 3

It is a plug and play fitment for Defenders after 1998. Earlier vehicles require soldering or connectors fitting.

DA8600LEDG - RING LED DAYTIME RUNNING LIGHTS

Pair

Fitted with 5 x 1.5w ultra bright LEDs
Dimensions - H 57 x W 145 x D 55mm
Voltage - 12 / 24V DC
Watts - 15W

39.00KWD

Defender

DA7610G - Indicator Lamp

Single

Was 8.02KWD

Orange Bulb - Clear

NOW 5.50KWD

Discovery 3
Discovery 4
Range Rover Sport Mk1

DA7611G - Indicator Lamp

Single

Was 7.29KWD

Orange Bulb - Clear

NOW 6.00KWD

Discovery 3
Discovery 4
Range Rover Sport Mk1

DA1192G - LED LIGHT KIT

Defender - 1987 - 2007

Was 47.65KWD

Series 2

NOW 39.00KWD

Series 3

It is a plug and play fitment for Defenders after 1998. Earlier vehicles require soldering or connectors fitting.



GL1192 - WIPAC LED LIGHT KIT FOR DEFENDER

Defender - 1987 - 2007

Series 3

Was 48.41KWD

4 x Front and Rear indicator - Amber

NOW 39.50KWD

2 x Stop/ tail light - Red

1 x Flasher relay for indicators

2 x Front side light - Clear



LR048201LED - REAR FOG LAMP

DEFENDER 2007 ONWARDS

Was 8.57KWD

NOW 7.00KWD



TF713 - TF PAIR OF 10W 800LM SPOT LED LIGHTS

These perfect little 50mm / 2" spotlights from Terrafirma have a single 10 watt LED chip, producing a super bright 800 Lumens of light with a 10-degree spot beam pattern ideal for projecting long distances.

Built into a black alloy housing with stainless steel mountings, these powerful lamps are ideal for mounting anywhere on your vehicle.

Was 36.06KWD

NOW 29.50KWD



TF7001 - STRAIGHT LIGHT BAR

Satin black powder coated steel tubular roof light bar

36.50KWD

Defender All





TF715 - TF EMERGENCY LIGHT-RECHARGEABLE

TF715 is a super handy lightweight, adjustable magnetic based, rechargeable work light with bright, medium and flash modes. Supplied with USB charge lead and cigar lighter plug.

- 12W output (4 x 3W LED)
- 1000 Lumen brightness - equivalent of 80 candles.
- 3.7V Lithium battery
- Up to 5hrs working life
- 8hr max charge time
- Magnetic Base
- Handle allows the lamp to be hand-held or free-standing
- Tilttable Lamp Head
- Three Light Modes - Bright, Dimmed and Flash
- Lightweight only 0.7kg
- Folds into a cube for easy and convenient storage
- Kit includes USB charging lead and car adaptor
- Tough, durable outer casing

Was 12.83KWD

NOW 18.50KWD



DA2231G - SANDTRACK

Pair

Was 56.10KWD

Aluminum

NOW 46.00KWD

1,500mm long x 390mm wide x 4mm thick



DA4587G—RECOVERY TRACKS

Pair - stackable (not in use)

Was 33.35KWD

Plastic

NOW 27.50KWD

1,210mm long x 325mm wide x 60mm deep

Max load - 3.5 tons



TF999 - TF SEMI-RIGID RECOVERY BOARDS

Terrafirma semi rigid plastic recovery boards are easy to handle and store on or in your 4x4, also known as traction ladders these treaded boards can reduce sinking and provide the increased grip that can often be all that's needed

34.50KWD



TF0012 - TF SKELETON ROCK SLIDERS - DEF 90

Terrafirma Skeleton rock sliders for Land Rover Defender 90, made from 3mm mild steel with punched and swaged slotted holes for weight reduction and styling, finished in lustrous satin black powder coat these rock sliders are chassis

Defender 90

Was 107.44KWD

NOW 87.50KWD



TF0013 - TF SKELETON ROCK SLIDERS FITS DEF 110

Terrafirma Skeleton rock sliders for Land Rover Defender 110, made from 3mm mild steel with punched and swaged slotted holes for weight reduction and styling, finished in lustrous satin black powder coat these rock sliders are chassis

Defender 110

Was 118.65KWD

NOW 96.50KWD



TF3311 - TF RECOVERY ROPE 22MM 13000KGS

Length - 9,000mm

Width - 22mm

Was 21.36KWD

Breaking strain - 13,000kg

NOW 17.50KWD

DA1283G - TOW STRAP

Length - 8,000mm

Was 4.87KWD

Width - 50mm

NOW 4.00KWD

Breaking strain - 5,000kg

.

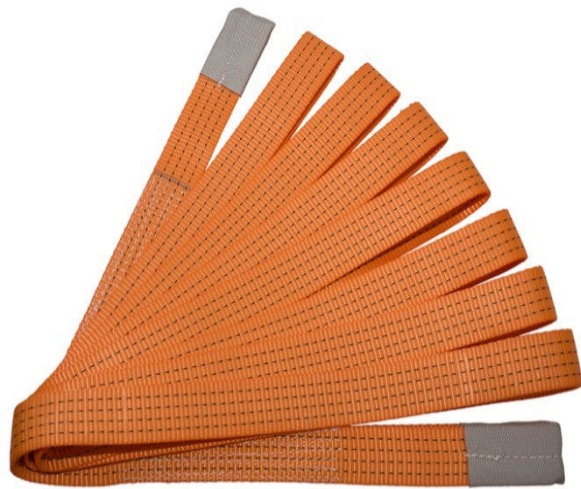

TF3310 - TF SOFT SHACKLE: 10MM / 7 TONNES

These shackles are made of 11mm synthetic rope and rated to 9 tonnes of load.

Was 7.15KWD

NOW 6.00KWD



DA7336G - ROPE SHACKLE

Pair

7.00KWD

Minimum breaking load - 5,830kgs

Manufactured from 11mm 12-strand UHMWPE rope with built in UV inhibitor. These are a lightweight, easy and safe way of joining ropes and strops. Due to the much lower kinetic energy being stored, using these shackles is much safer in the event of a rope or strop failure. Can also be used to attach ropes to standard towing eyes without scratching the paintwork.



DA3209G— SILICONE TURBO HOSE KIT

Was 14.72KWD

Engine to intercooler

NOW 12.00KWD

Equivalent to LR066344

Quality silicone hoses are designed to operate at a higher temperature than the original hoses.

Will not rot or perish like rubber hoses.

Defender - 2007 onwards



DA3174BG - SILICONE TURBO HOSE KIT

Intercooler hose kit

42.00KWD

2 piece kit

Quality silicone intercooler hoses designed to operate at a higher temperature than the original hoses.

Fits with both standard and performance intercoolers.

Will not rot or perish like standard rubber hoses.

Defender - 2.4 Tdci





DA3210G - SILICONE TURBO HOSE KIT

Air inlet connector

Equivalent to LR067644

Quality silicone hoses are designed to operate at a higher temperature than the original hoses.

Will not rot or perish like rubber hoses.

Defender - 2007 onwards

22.00KWD



DA4575 - SILICONE COOLANT HOSE KIT

Coolant hose kit

5 piece kit

Quality silicone hoses are designed to operate at a higher temperature than the original hoses.

Will not rot or perish like rubber hoses.

Defender - 2.4TdcI - 2007 - 2012

Was 50.74KWD

NOW 41.50KWD



DA1955 - RED BOOSTER SERVO CLUTCH KIT

Left hand drive

Defender - 200Tdi & 300Tdi

This kit will make your driving a more pleasurable experience and reduce the effort you'd normally put in from driving your Defender. No more painful knees or feet when you are stuck in slow-moving traffic! Designed, engineered and manufactured to the highest standards, Red Booster is a mechanism system that makes it possible for all Defenders to have a servo-assisted clutch.

Working in a similar way to the braking system with a servo-assisted system, it is mounted between the pedal and master cylinder and uses a vacuum from the inlet manifold to reduce the amount of pressure needed on the pedal to operate the clutch.

The left-hand drive version - works similar to the right-hand drive system. The location of the clutch pedal of a left-hand drive Defender is on the far corner of the vehicle and with hardly any space the entire unit had to be redesigned to fit without cutting and drilling your vehicle.

Was 179.18KWD

NOW 145.50KWD